

Beneath

by Brian Mudgett
Alan Keown

♩ = 164

The score is for a marching band piece in 4/4 time with a tempo of 164. It features a variety of instruments and dynamic markings. The Snare and Tenor parts play a complex rhythmic pattern of triplets and sixteenth notes, with dynamics ranging from *p* to *ff*. The Bass Drums play a steady pattern of eighth notes, with some sixteenth-note runs. The Synthesizer 1 and 2 parts use samples of a Synth Lead and a Warm Choir, both starting at *f*. The Marimba 1, 2, Vibraphone 1, and Vibraphone 2 parts play a melodic line of eighth notes, with dynamics starting at *f*. The Timpani part plays a series of accented eighth notes, with dynamics starting at *sfz*. The Drum Set part includes Snare and Toms, with dynamics starting at *f*. The Percussion part includes Bass Drum and Tam Tam, with dynamics starting at *f*. The score is divided into 14 measures, with measure numbers 1 through 14 indicated at the bottom.

Beneath
Full Score

27

Snare

Tenor

Bass Drums

Synthesizer 1

Synthesizer 2

Xylophone

Marimba 1

Marimba 2

Vibraphone 1

Vibraphone 2

Timpani

Drum Set

Percussion

mf p mf p mf

mf p mf

mf

mf

Xylophone

mf

mf

mf

Vibes

mf

Hi-Hat

mf

mf

24 25 26 27 28 29 30 31 32 33

Beneath
Full Score

Snare

Tenor

Bass Drums

Synthesizer 1

Synthesizer 2

Xylophone

Marimba 1

Marimba 2

Vibraphone 1

Vibraphone 2

Timpani

Drum Set

Percussion

45 46 47 48 49 50 51 52 53 54 55

f *p* *mf* *mp* *mf* *mf*

(X) (X)

R R L L R R L L R L L R R L L R R L L

Bells *mf*

Vibraphone *mf*

Vibraphone *mf*

Snare

Beneath

by Brian Mudgett
Alan Keown

♩ = 164

1 *p* *mf* *ff* *f*

7

19 *p* *mf* *p* *p*

27 *mf* *p* *mf* *p* *mf* *p*

35 *f*

41 *p* *ff* *f* *p*

56 *mf* *ff*

62 *f*

67

71 *p* *ff*

75 79 85 90

75

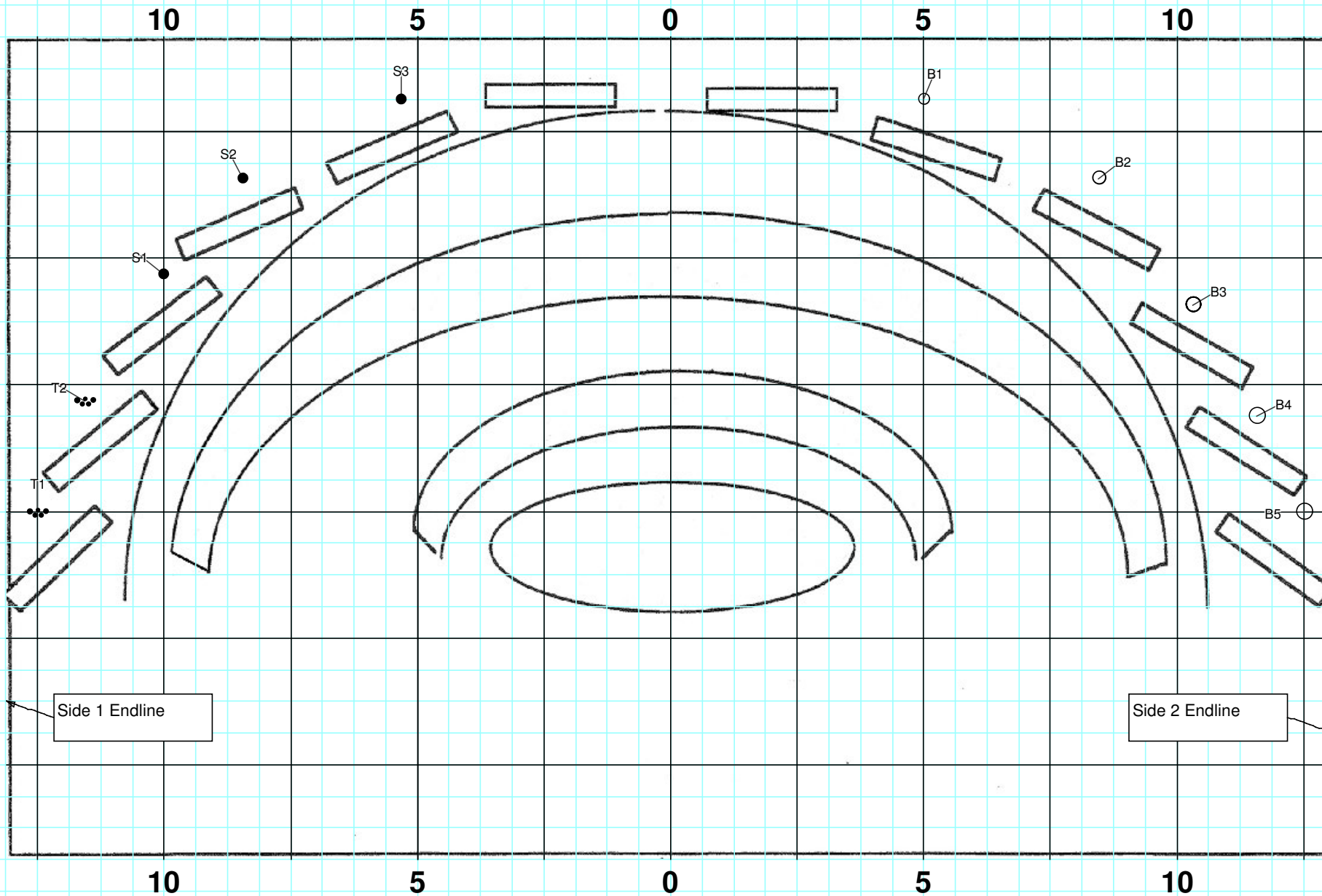

Beneath
Indoor Percussion Series
Level 4

SET UP CHART FOR
3 Snares
2 Tenors
5 Bass Drums

INSTRUMENTATION CODES
S - Snare
T - Tenor
B - Bass Drum

Copyright 2007
Marching Show Concepts
All Rights Reserved

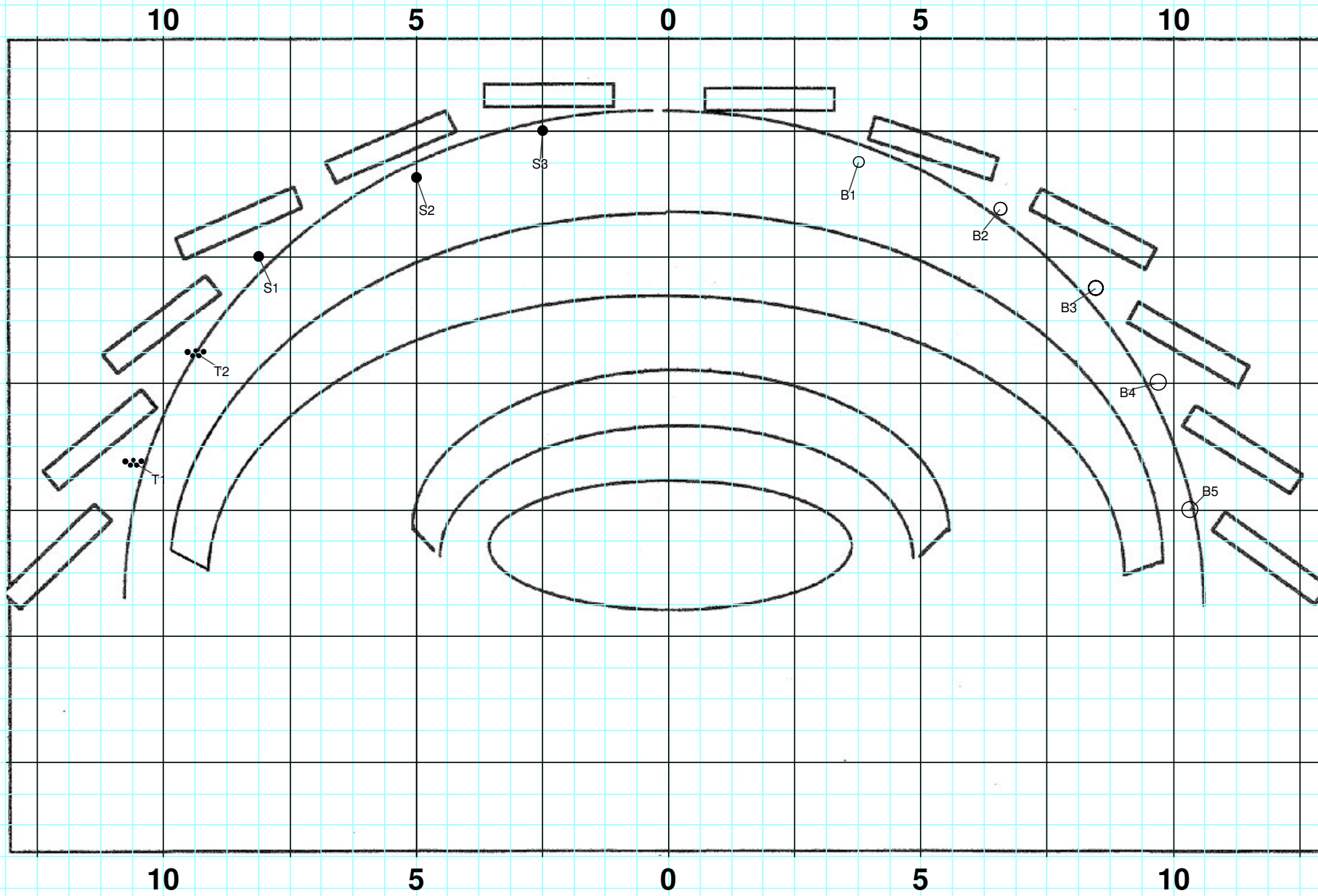

Beneath
Measures 1 - 3 / 14 counts

S - Float 6, Hold 8
T - Hold 6, Float 6, Hold 2
B - Hold 12, Float 2

Director Viewpoint

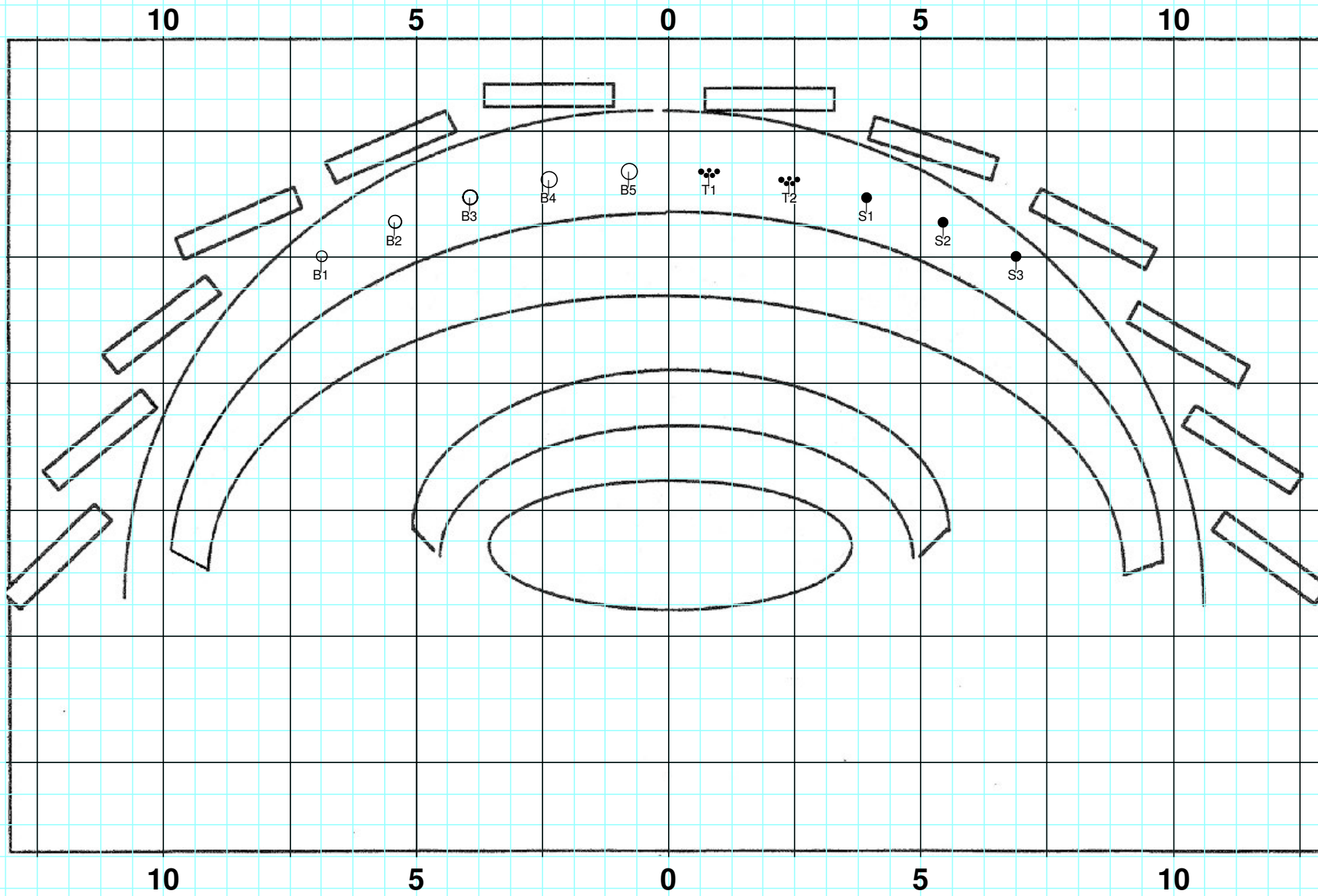

Beneath
Measures 4 - 14 / 24 counts
All - Float 20, Hold 4
Note: S / T should move in front of B

Director Viewpoint

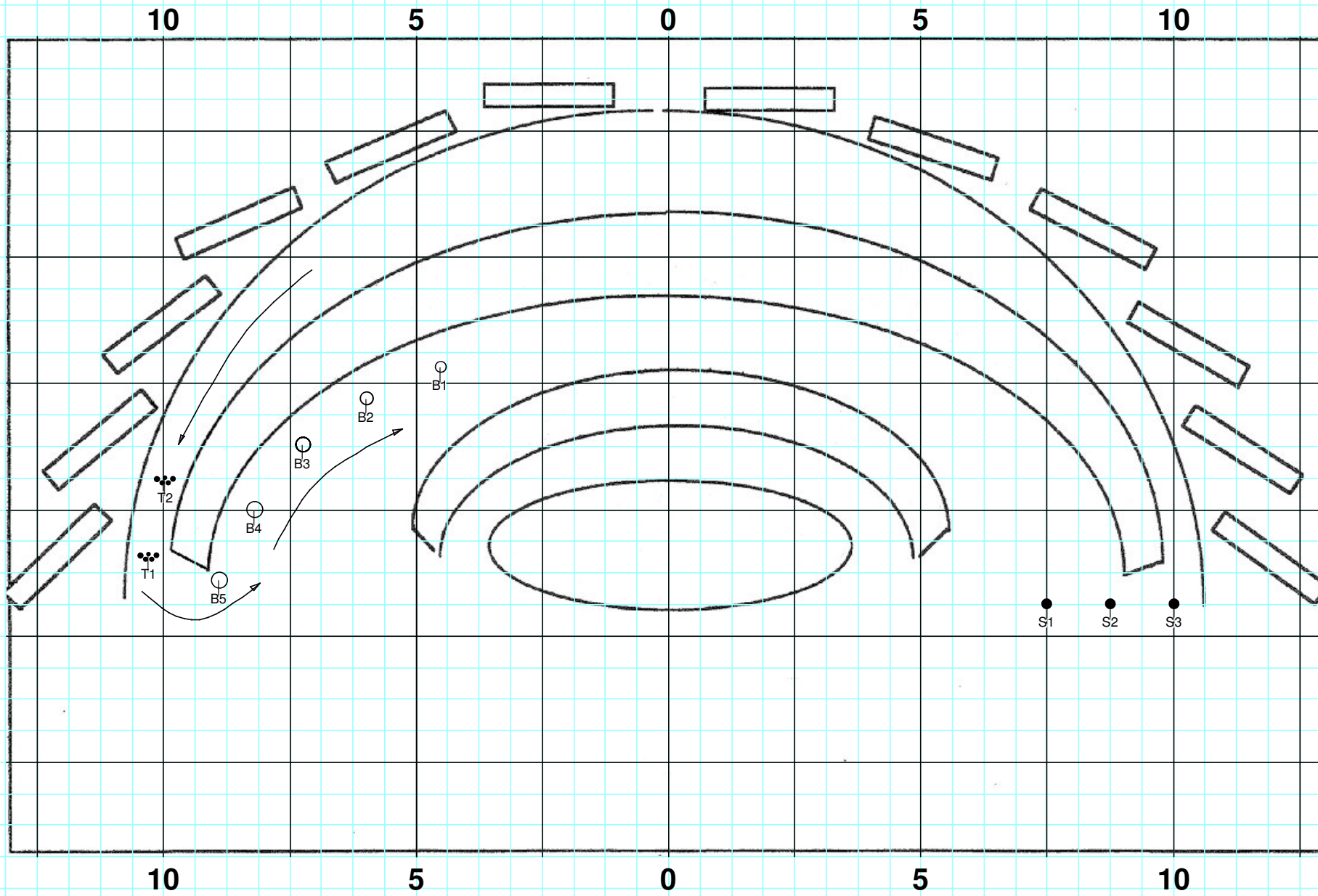

Beneath
Measures 15 - 18 / 16 counts

S - Float 16
T / B - Follow the Leader 16

Director Viewpoint

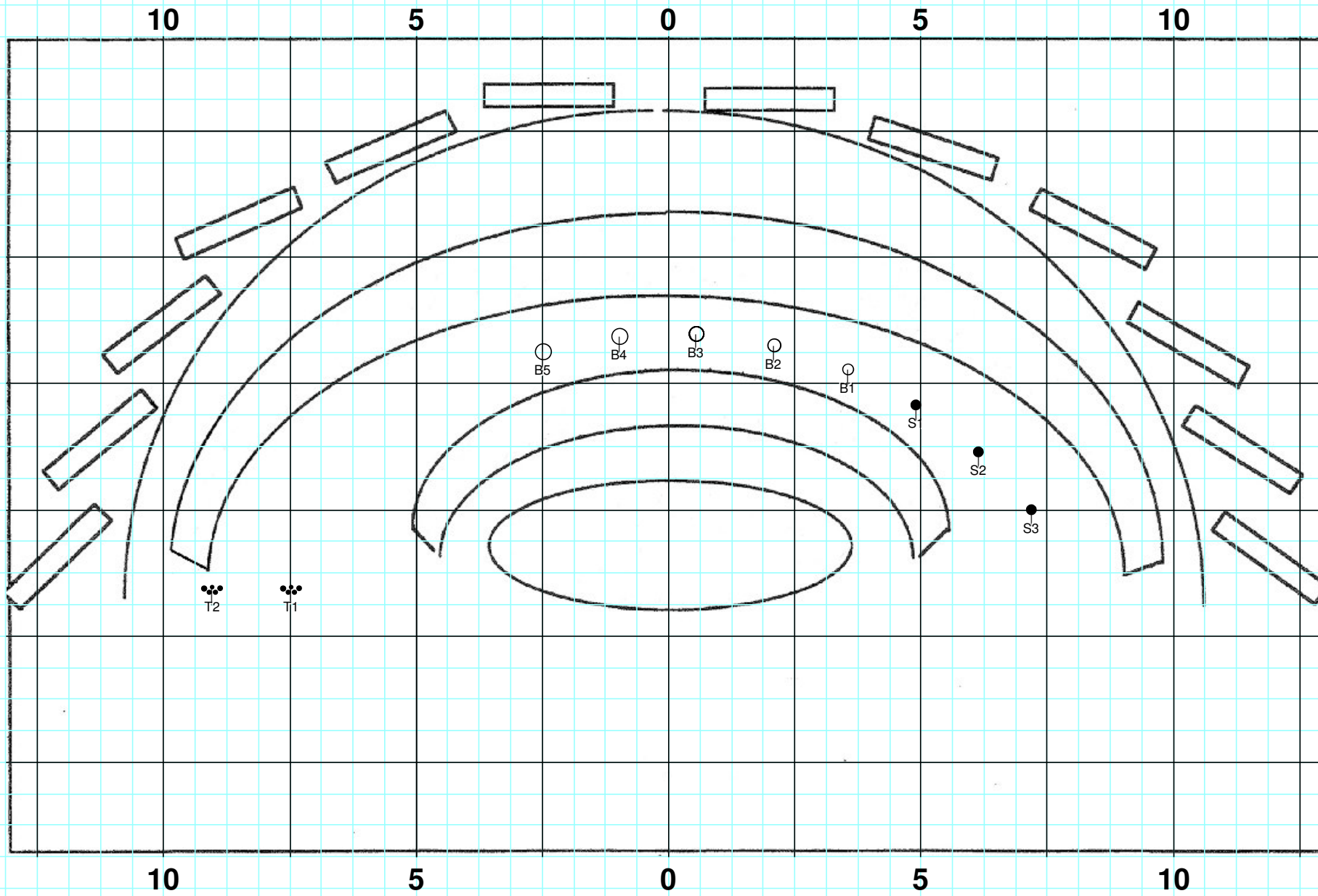

Beneath
Measures 19 - 22 / 16 counts

S - Hold 8, Float 8
T - Float 8, Hold 8
B - Float 16

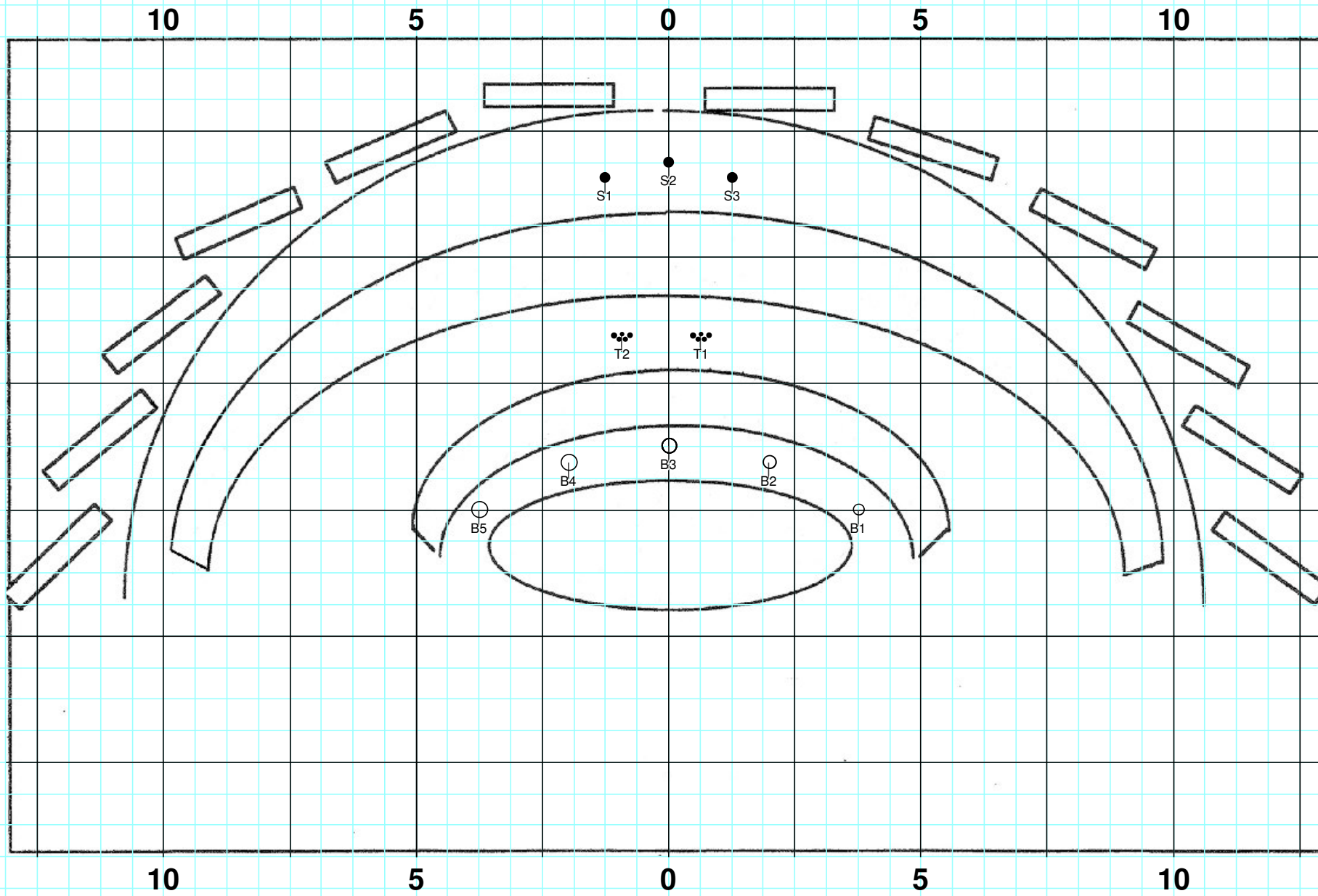

Beneath
Measures 23 - 26 / 16 counts

S - Float 12, Hold 4
T - Follow the Leader 12, Hold 4
B - Float 4 in half time (8 counts), Hold 8